

REVISION RECORD			
REV.	CONTENT	MOD.	DATE
△	初版发行		

技术要求:

1. 材质: 黄铜, 厚度1mm.
2. 打铜底2um, 镀镍2um, 镀锡4um.
3. 螺牙扭力矩达到1.8N.m以上, 符合M4-6H的螺纹规检测, 螺牙不能有乱牙、豁牙、滑牙现象.
4. 不得有变形, 毛刺等缺陷.
5. 方垫铆好后不得有松动现象.
6. 适用线规格: 24-10AWG
7. 额定电流: 50A

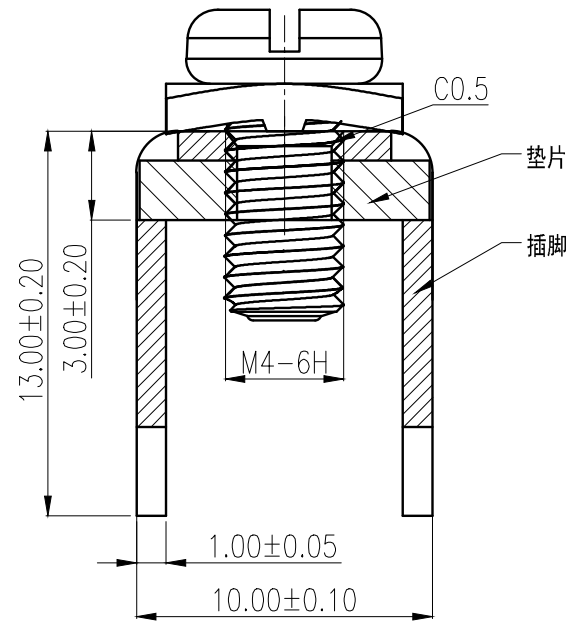
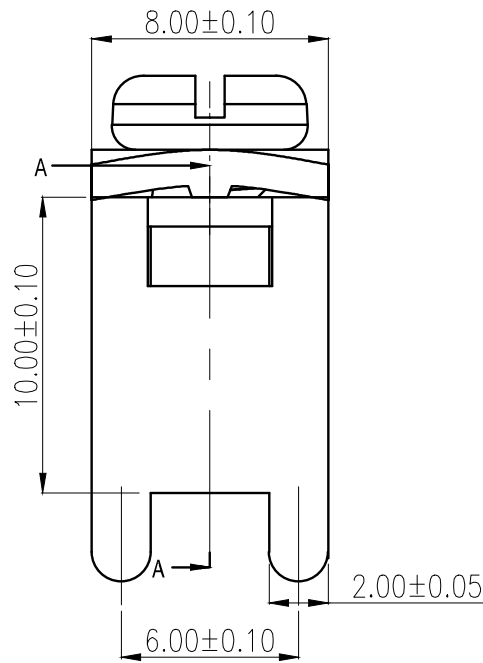

SECTION A-A

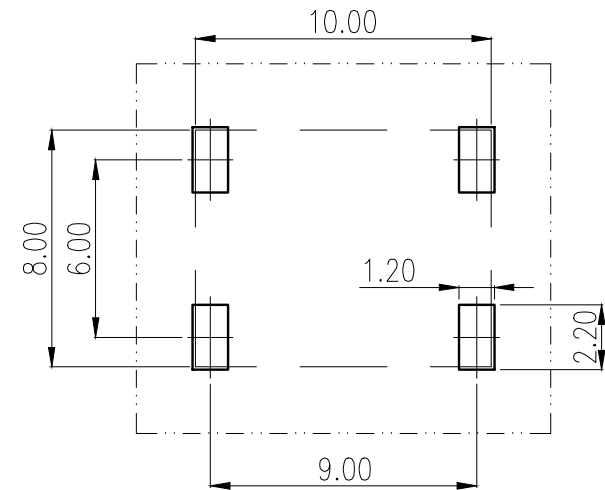

	pitch dimension			Nominal dimension					— /
	over 0	over 6	over 10	over 0	over 30	over 60	over 100	over 150	
variable range	to 6	to 10	to 24	to 30	to 60	to 100	to 150		□ ○
Tolerance	±0.1	±0.15	±0.25	±0.2	±0.3	±0.5	±0.7	±1.0	0.05/10

3	4*8-8*8环保蓝白锌	4*8-8*8R0SHLXB		碳钢	环保蓝白锌
2	方形垫片			碳钢	
1	E6.0*10.0*13.0/4*M4-T-2			黄铜	镀雾锡
NO.	NAME OF PART	NO. OF PART	Q'TY	MATERIAL	NOTES
DES.	ZJL	DATE	2021/09/17	UNITS	mm
CHK.		DATE		SIZE	A4
APP.		DATE		SCALE	1:1
上海有乐电气有限公司 Shanghai YouLe Electric CO.,LTD				TITLE	E6.0*10.0*13.0/4*M4/8*8-T-2
					E6.0*10.0*13.0/4*M4/8*8-T-2产品